

# 150 WATT LED COMMERCIAL HIGH BAY

**PART NO: HBS150**

**MATERIAL:**

- High-efficiency Aluminum Reflector, hanging hook
- Aluminum Alloy Housing
- Acrylic Glass Lens
- High Power LED Light Source/Bridgelux array
- High Efficiency LED Driver



**PRODUCT FEATURES:**

- Universal AC Input /Full Range
- Built-In active PFC function
- High Efficiency - up to 93.5%
- IP65 Design Indoor/Outdoor Installation
  
- Replaces a Standard 400W HID

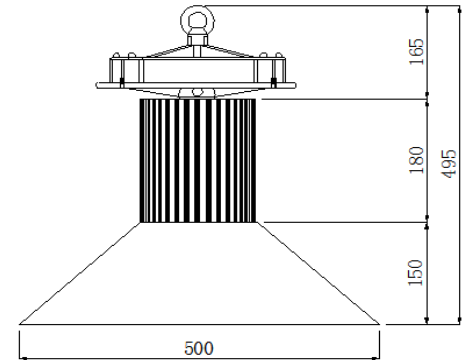

<b>Working Voltage</b>	100-277VAC/50Hz-60Hz
<b>LED power consumption</b>	97W
<b>System power consumption</b>	150W
<b>LED Luminous Efficacy</b>	95 - 105 Lm/W
<b>LED Initial Flux</b>	14,250 – 15,750 Lm
<b>Lamp Efficiency</b>	>90 %
<b>Luminance Uniformity</b>	>15%
<b>CCT</b>	3000-5000K
<b>Color Rendering Index</b>	>80
<b>Light Distribution</b>	Symmetric/round optical spot
<b>IP Grade</b>	IP65
<b>Net Weight</b>	13.8 lbs
<b>Working Life-Span</b>	50,000H
<b>Warranty</b>	5 Years

**SAMPLE ORDERING NUMBER: HBS150VDLAR1**

<b>HB</b> Type	<b>S</b> Series	<b>150</b> Watts	<b>A</b> Voltage	<b>DL</b> ColorTemp	<b>A</b> BodyColor	<b>R1</b> Reflector
-------------------	--------------------	---------------------	---------------------	------------------------	-----------------------	------------------------

Series	Watts	Voltage	Color Temp	Body Color	Reflector
S - Standard	150	V - 100-277	SW - Soft White	A - Aluminum	R1 - 120 Degree
E -Energy Star			DL - Day Light		R2 - 90 Degree
					R3 - 45 Degree
					R4 - Upgrade/Acrylic

# 150 WATT LED COMMERCIAL HIGH BAY

## Curve Graph of Light Distribution

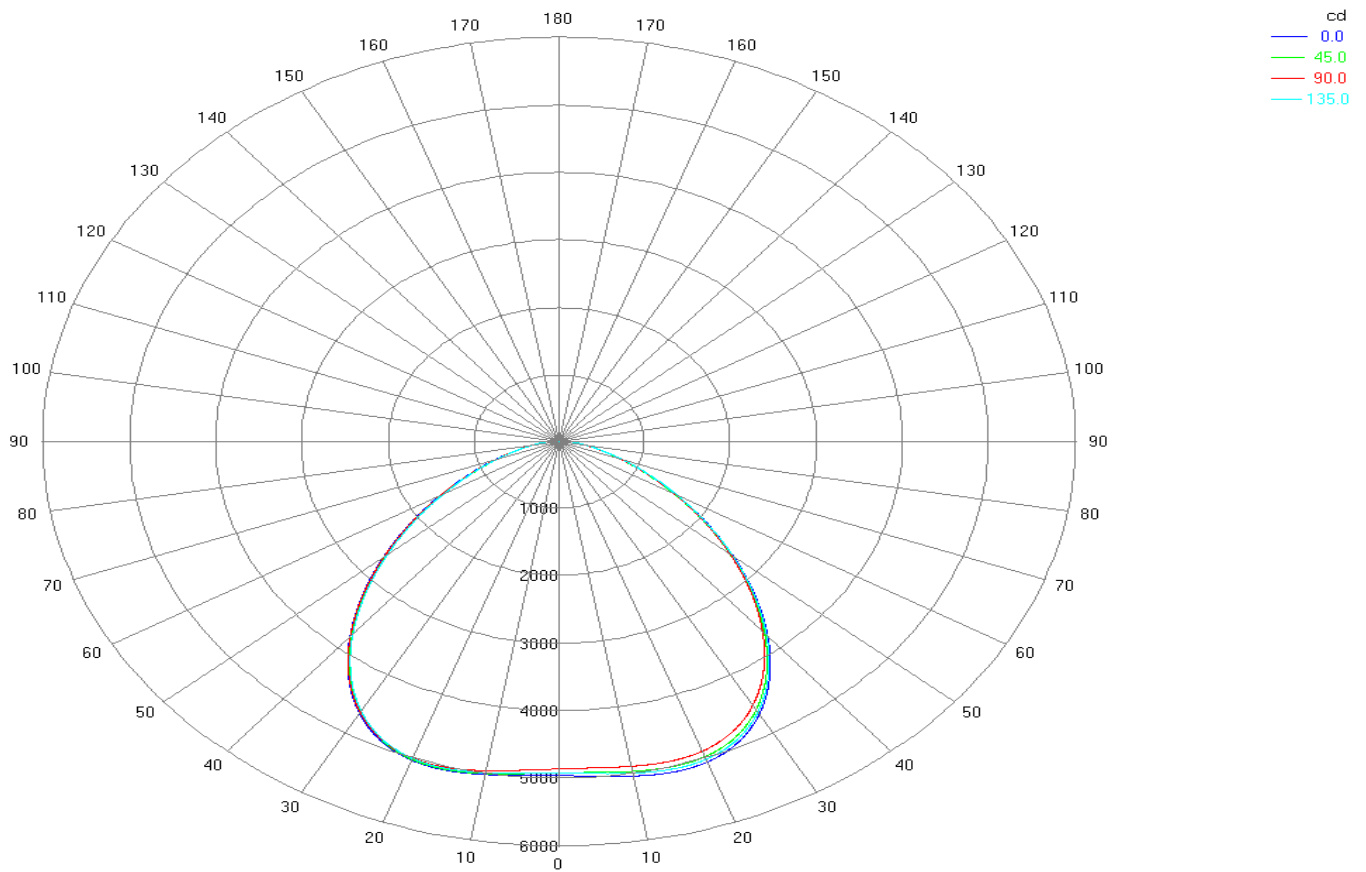

## Effective Average Illuminance

